



**AGENDA  
CITY OF EL SEGUNDO  
ARTS & CULTURE ADVISORY  
COMMITTEE  
5:30 PM  
EL SEGUNDO PUBLIC LIBRARY  
SUE CARTER ROOM  
111 W. MARIPOSA AVEUNE  
EL SEGUNDO, CA 90245  
AUGUST 27, 2024**

---

**MEMBERS OF ARTS & CULTURE ADVISORY COMMITTEE**

John Pickhaver, Chairperson  
David Bart, Vice Chairperson  
Jane Burrell  
Brian Mitchell  
Joan Palmer  
Michael Schepps  
Tanya Taylor  
Vacant (4)

The Arts & Culture Advisory Committee, with certain statutory exceptions, can only take action upon properly posted and listed agenda items. Any writings or documents given to a majority of the Arts & Culture Advisory Committee, regarding any matter on this agenda, that the City received after issuing the agenda packet are available for public inspection in the public library at the Help Desk, during normal business hours. Such documents may be posted on the City's website at [www.elsegundo.org](http://www.elsegundo.org) and additional copies will be available at the meeting.

Unless otherwise noted in the agenda, the public can only comment on city-related business that is within the jurisdiction of the Arts & Culture Advisory Committee and/or items listed on the agenda during the Public Communications portion of the Meeting. The time limit for comments is five (5) minutes per person. Before speaking to the Arts & Culture Advisory Committee, please state: your name, residence, and organization/group you represent, if desired. Please respect the time limits.

***REASONABLE ACCOMMODATIONS: In compliance with the Americans with Disabilities Act and Government Code Section 54953(g), the City Council has adopted a reasonable accommodation policy to swiftly resolve accommodation requests. The policy can also be found on the City's website at <https://www.elsegundo.org/government/departments/city-clerk>. Please contact the City Clerk's Office at (310) 524-2308 to make an accommodation request or to obtain a copy of the policy.***

*Land Acknowledgment: We acknowledge that we are holding this meeting on the traditional, ancestral, and unceded territory of the Tongva. We recognize the Tongva people as the traditional land caretakers of Tovaangar (Los Angeles basin, So. Channel Islands). We also acknowledge that Los Angeles County is home to the largest Indigenous population in the United States.*

**CALL TO ORDER/ROLL CALL**

**PLEDGE OF ALLEGIANCE**

**PUBLIC COMMUNICATION – (Related to City Business Only – 5-minute limit per person, 30-minute limit total)** *Individuals who have received value of \$50 or more to communicate to the **Arts & Culture Advisory Committee** on behalf of another, and employees speaking on behalf of their employer, must so identify themselves prior to addressing the **Arts & Culture Advisory Committee**. Failure to do so shall be a misdemeanor and punishable by a fine of \$250. While all comments are welcome, the Brown Act does not allow action on any item not on the agenda.*

**A. CONSENT**

1. **Arts and Culture Advisory Committee Meeting Minutes**

---

Recommendation -

1. Approve Regular Committee meeting minutes of July 23, 2024.
2. Alternatively, discuss and take other action related to this item.

**B. NEW BUSINESS**

2. **Hilton Garden Inn 1% Public Art Proposal**

---

Recommendation -

1. Approve the Hillton Garden Inn Public Art proposal as presented.
2. Alternatively, discuss and take other action related to this item.

3. **Art Walk Recap**

---

Recommendation -

1. Accept and file update report.
2. Alternatively, discuss and take other action related to this item.

4. **Programming Updates**

---

Recommendation -

1. Accept and file update report.
2. Alternatively, discuss and take other action related to this item.

**5. Cultural Development Program Updates**

Recommendation -

---

1. Accept and file update report.
2. Alternatively, discuss and take other action related to this item.

**6. Cultural Arts Plan Updates**

Recommendation -

---

1. Accept and file update report,
2. Alternatively, discuss and take other action related to this item.

**7. Public Art Updates**

Recommendation -

---

1. Accept and file update report.
2. Alternatively, discuss and take other action related to this item.

**8. ACC Meeting Schedule**

Recommendation -

---

1. Discuss and determine special meeting dates for November and December meetings.
2. Alternatively, discuss and take other action related to this item.

**C. UNFINISHED BUSINESS**

**9. Juneteenth Update**

Recommendation -

---

1. Accept and file update report.
2. Alternatively, discuss and take other action related to this item.

**10. ACC Vacancy Update**

Recommendation -

---

1. Accept and file update report.
2. Alternatively, discuss and take other action related to this item.

**11. GUNDO Pride Update**

---

Recommendation -

1. Accept and file update report.
2. Alternatively, discuss and take other action related to this item.

**D. REPORTS - BUDGET & INITIATIVE COMMITTEE**

**E. REPORTS - SUBCOMMITTEES**

**F. REPORTS - ARTS & CULTURE ADVISORY COMMITTEE MEMBERS**

**G. REPORTS - COUNCIL MEMBER LIAISON**

**H. REPORTS - RECREATION, PARKS AND LIBRARY DIRECTOR**

**ADJOURNMENT**

POSTED:

DATE: 08/23/2024

TIME: 4:30 PM

BY: Chelsea Shafer

REGULAR MEETING MINUTES OF THE EL SEGUNDO ARTS AND CULTURE  
ADVISORY COMMITTEE  
TUESDAY, JULY 23, 2024

- A. CALL TO ORDER – Vice Chairperson Burrell called the meeting to order at 5:30pm.

ROLL CALL

Chairperson Pickhaver	-	Absent
Vice Chairperson Burrell	-	Present
Member Mitchell	-	Present
Member Von Flue	-	Present
Member Bart	-	Absent
Member Schepps	-	Present
Member Palmer	-	Present
Member Taylor	-	Absent
Councilmember Giroux	-	Absent

- B. PUBLIC COMMUNICATIONS – (Related to City Business Only – 5-minute limit per person, 30-minute limit total)

None

- C. CONSENT CALENDAR:

1. MOTION by Member Palmer, SECONDED by Member Bart, approving Regular Committee meeting minutes of June 11, 2024 MOTION PASSED.  
5/0

- D. UNFINISHED BUSINESS

1. ACC Vacancy Updates

Cultural Arts Coordinator Randy Niessen provided an update and reported on the item including advertising plans and expected dates from fulfilling the vacancies.

- E. NEW BUSINESS

1. Art Walk Updates

Cultural Arts Coordinator Randy Niessen provided an update and reported on the item including artist applicants, shuttles for the event, Songwriters in the Round collaboration with the Art Walk, and Art Walk logistics for the event.

## 2. Programming Updates

Cultural Arts Coordinator Randy Niessen provided an update and reported on the item including the application deadline extension and evaluation, an art excursion, exhibition updates, and future special events.

## 3. Cultural Development Program Updates

Cultural Arts Coordinator Randy Niessen provided an update and reported on the item including current permits, additions to the art fund, and council-directed program campaign.

## 4. Cultural Arts Plan Updates

Cultural Arts Coordinator Randy Niessen provided an update and reported on the item including postponing the first meeting until a later date.

## 5. GUNDO Pride

Item to be reported on during the August 27<sup>th</sup> meeting.

## 6. Diversity, Equity, and Inclusion (DEI) Committee Collaboration

Cultural Arts Coordinator Randy Niessen provided an update and reported on the item including potential United Against Hate Week collaboration.

## F. REPORTS

### 1. DIRECTOR'S REPORT

None

### 2. COMMITTEE MEMBER COMMENTS

Member Bart asked for additional information regarding the summer concert series. Cultural Arts Director Randy Niessen responded and provided feedback.

Member Von Flue commented on the budget allocation of the Plunge Capital Improvement Projects.

Member Bart thanked Member Von Flue for his service to the Committee.

### 3. STAFF COMMENTS

Cultural Arts Coordinator Randy Niessen commented on the progress of various Capital Improvement Projects such as the Plunge and the Lighting project.

Adjourned at 6:13 PM

*Chelsea Shafer*

---

Chelsea Shafer, Senior Administrative Specialist for  
Randy Niessen, Cultural Arts Coordinator

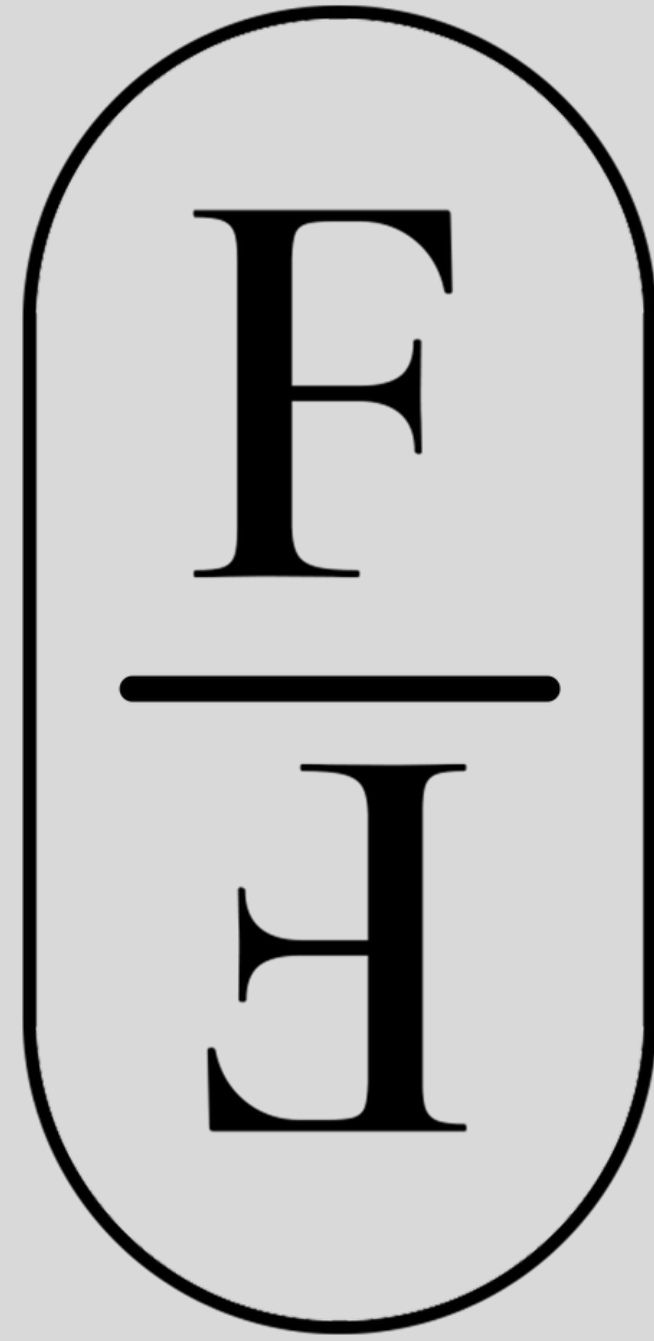

FORMED FOR



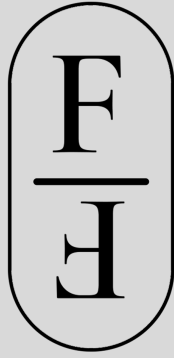

FORMED FOR

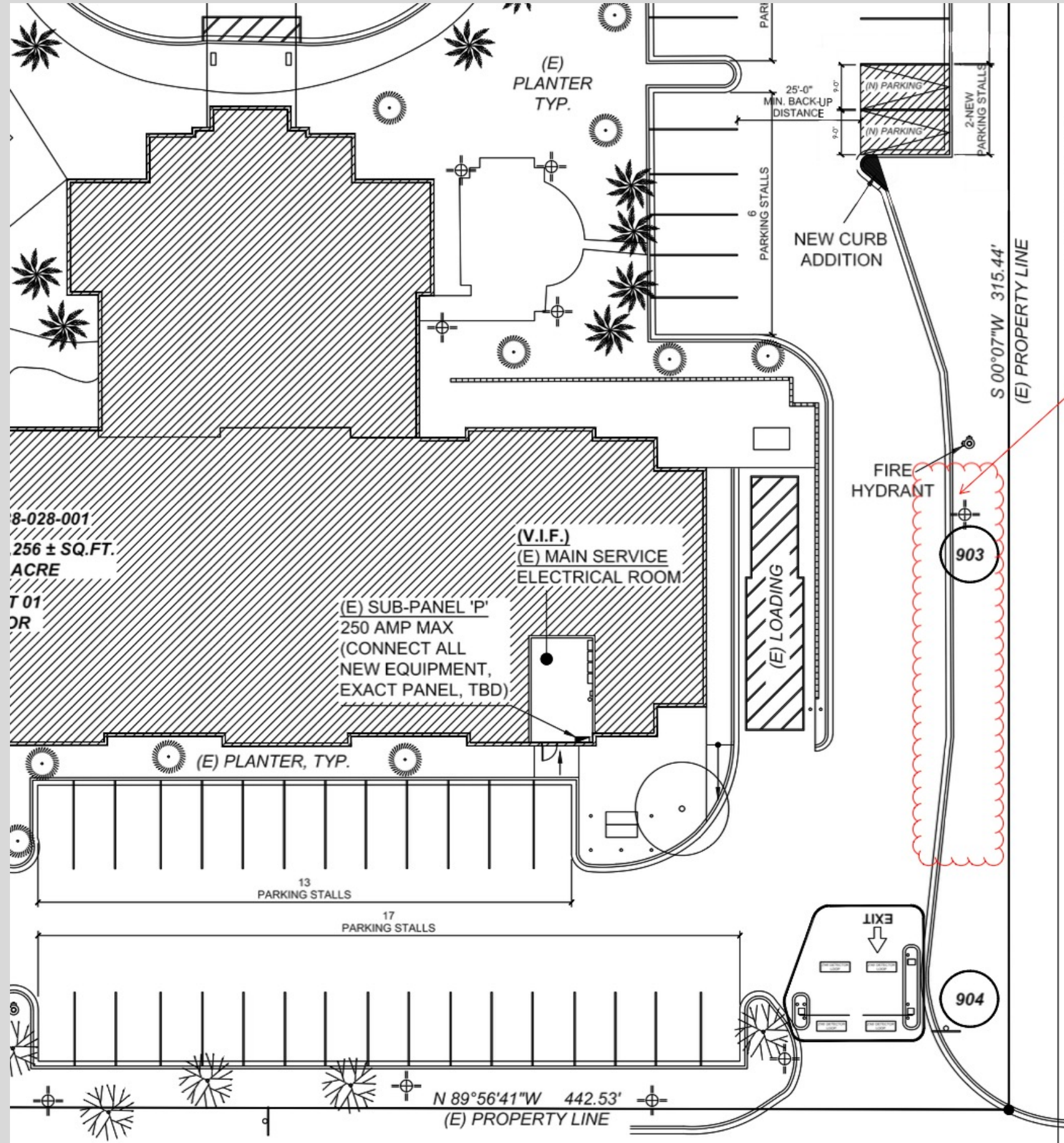

Art installation

PROJECT:

HILTON GARDEN INN  
EL SEGUNDO, CA

HGI  
EL SEGUNDO  
PUBLIC AREAS  
2100 E MARIPOSA AVENUE  
EL SEGUNDO, CA

DRAWN: JTM

110 W. 11TH STREET SUITE #150 LOS ANGELES CA 900

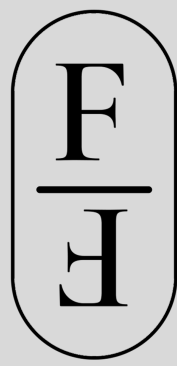

FORMED FOR

"Cortex Waves" is a profound symbol of connection and community. Crafted from the strength and resilience of Corten Steel, the sculpture's fluid, undulating form mirrors the ever-moving waves of the ocean, embodying the ebb and flow of human interactions. The waves represent the interconnectedness of individuals within a community, each wave blending seamlessly into the next, illustrating how we are all part of a larger whole.

This piece serves as a reminder that, like the ocean's waves, our actions and relationships ripple outward, impacting those around us. Through its dynamic design and robust material, "Cortex Waves" emphasizes the enduring bonds that unite us, celebrating the power of unity and collective strength in forging a harmonious community.

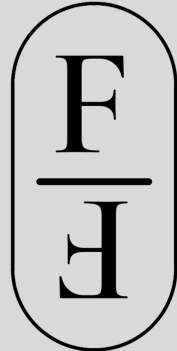

FORMED FOR

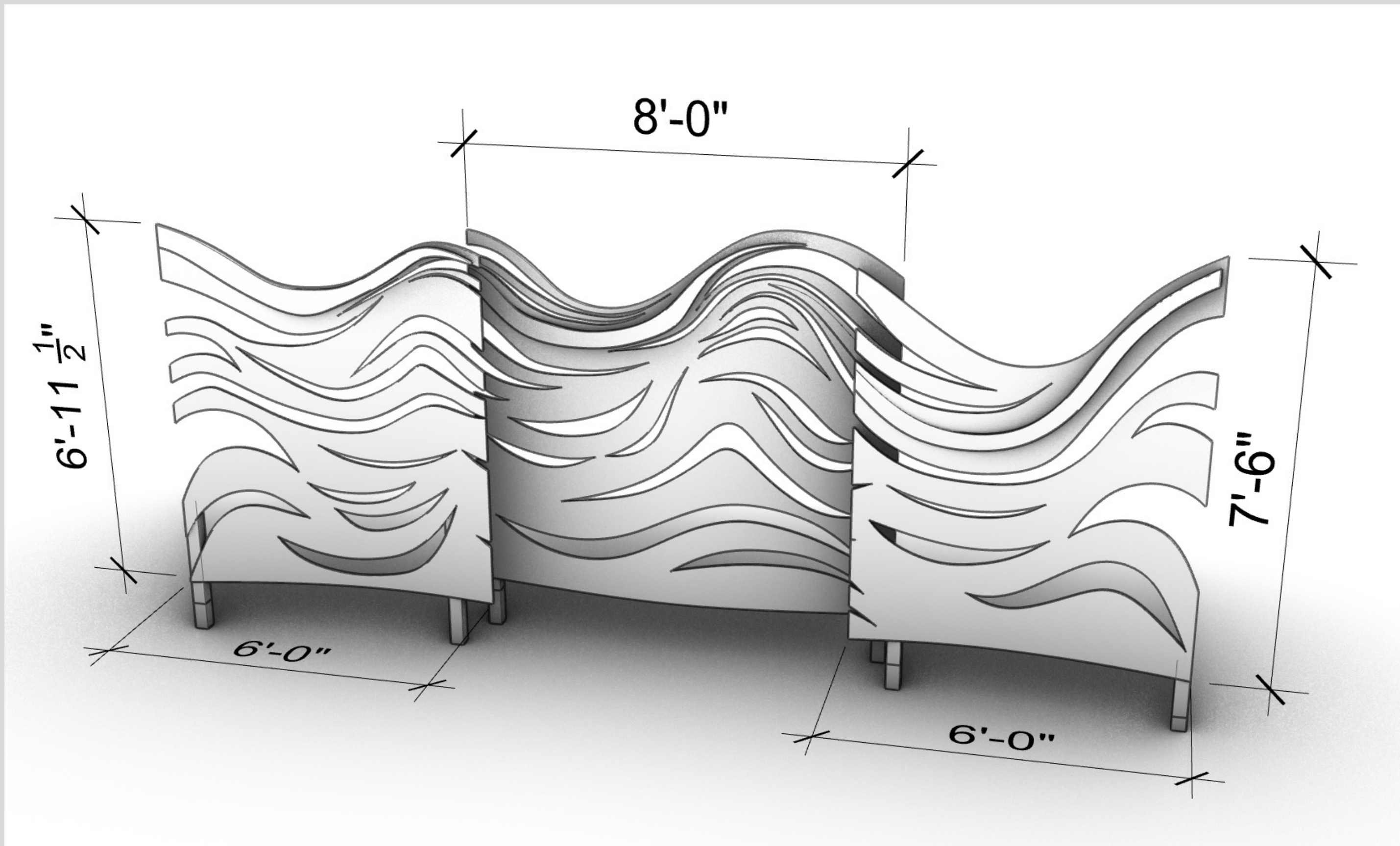

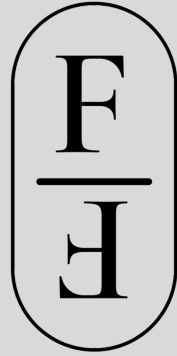

FORMED FOR

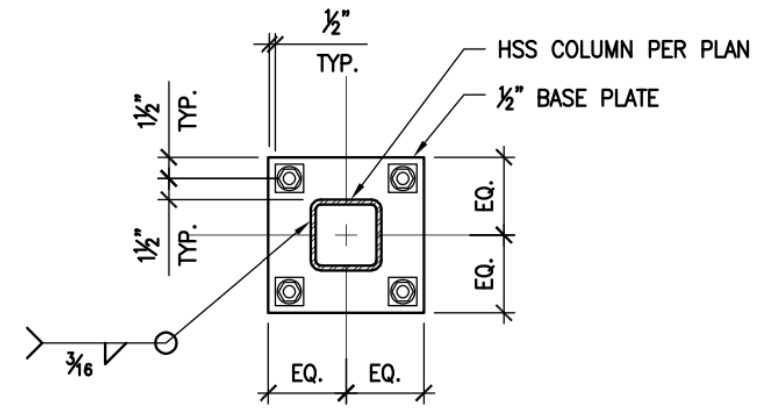

E: FOUR BOLT PATTERN

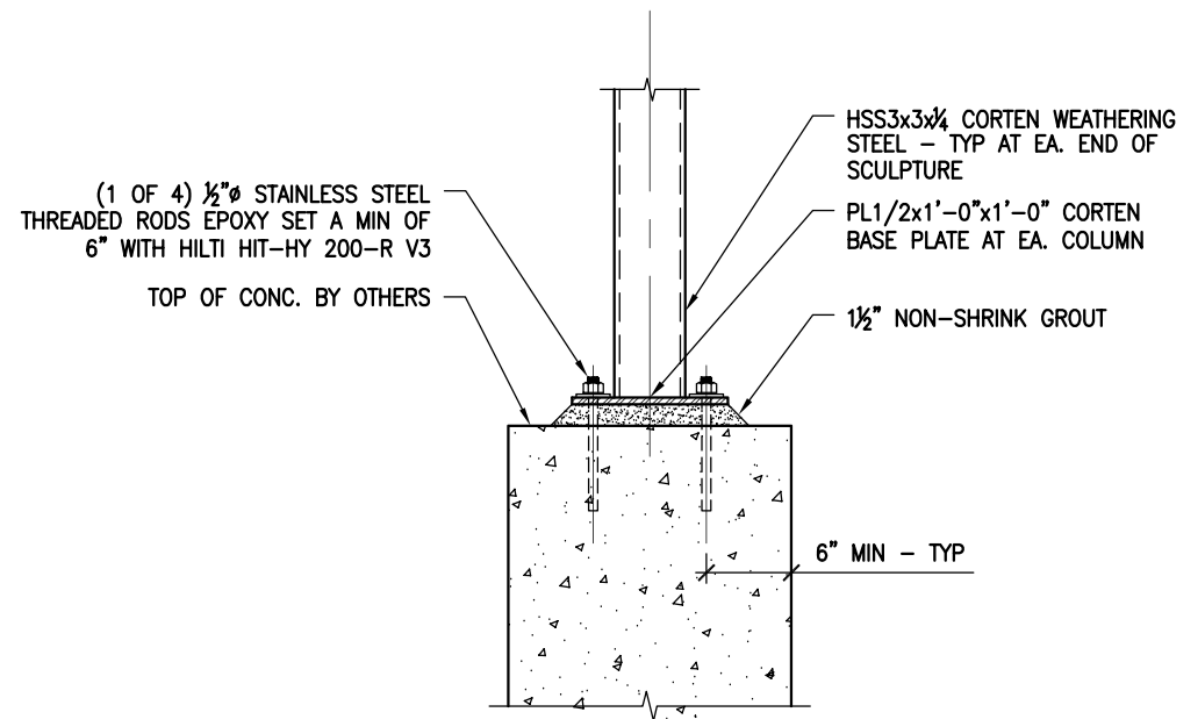

NOTE:  
1/16 inch MAX. OVERSIZE HOLES IN BASE PLATE. 3/16 inch MAX. OR OVERSIZE HOLES IN BASE PLATE WITH 2"x2"x3/16 inch PLATE WASHERS WITH 1/16 inch OVERSIZE HOLES. WELD WASHERS TO BASE PLATE.

1

## HSS COLUMN BASE PLATE CONNECTION

3/4" = 1'-0"

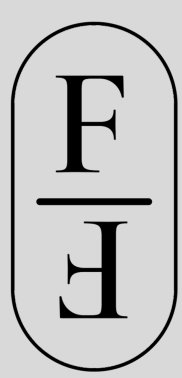

FORMED FOR



This sculpture is very easy to sand / prep and re-age into  
The current finish which is an aged Corten Steel

Uplighting needed in the landscaping –provided by others

"Cortex Waves" is a profound symbol of connection and community. Crafted from the strength and resilience of Corten steel, the sculpture's fluid, undulating form mirrors the ever-moving waves of the ocean, embodying the ebb and flow of human interactions. The waves represent the interconnectedness of individuals within a community, each wave blending seamlessly into the next, illustrating how we are all part of a larger whole.

This piece serves as a reminder that, like the ocean's waves, our actions and relationships ripple outward, impacting those around us. Through its dynamic design and robust material, "Cortex Waves" emphasizes the enduring bonds that unite us, celebrating the power of unity and collective strength in forging a harmonious community.

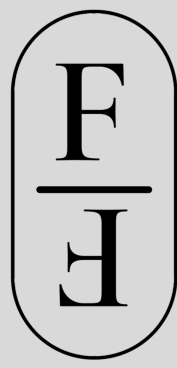

FORMED FOR



This sculpture is a little more complicated to fix after graffiti.

LED lights can be added into the top trim

"Cortex Waves" is a profound symbol of connection and community. Crafted from the strength and resilience of Corten steel, the sculpture's fluid, undulating form mirrors the ever-moving waves of the ocean, embodying the ebb and flow of human interactions. The waves represent the interconnectedness of individuals within a community, each wave blending seamlessly into the next, illustrating how we are all part of a larger whole.

This piece serves as a reminder that, like the ocean's waves, our actions and relationships ripple outward, impacting those around us. Through its dynamic design and robust material, "Cortex Waves" emphasizes the enduring bonds that unite us, celebrating the power of unity and collective strength in forging a harmonious community.

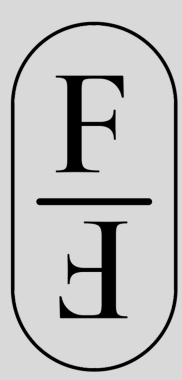

FORMED FOR



This sculpture with mesh incorporated looks good but Very difficult to remove graffiti.

LED lights can be added into the top trim

"Cortex Waves" is a profound symbol of connection and community. Crafted from the strength and resilience of Corten steel, the sculpture's fluid, undulating form mirrors the ever-moving waves of the ocean, embodying the ebb and flow of human interactions. The waves represent the interconnectedness of individuals within a community, each wave blending seamlessly into the next, illustrating how we are all part of a larger whole.

This piece serves as a reminder that, like the ocean's waves, our actions and relationships ripple outward, impacting those around us. Through its dynamic design and robust material, "Cortex Waves" emphasizes the enduring bonds that unite us, celebrating the power of unity and collective strength in forging a harmonious community.